



PHOENIX AMERICA INC.

4717 CLUBVIEW DRIVE
FORT WAYNE, IN 46804

P9100

MEDIUM RESOLUTION TACHOMETER/ENCODER

Features:

- Up to 30 PPR Digital Output Signal
- 4.5-24 VDC Operation Range
- Current Sinking Output
- Short Circuit Protection
- Reverse Polarity Protection
- 0 to 100 kHz Operation
- Temperature Compensated
- Operation from -40°C to 125°C
- Rugged, PPS thermoplastic housing
- Wide range of standard magnet targets



Tachometer/Encoder Description:

The P9100 Series is by design, a rugged cost-effective industrial grade product. Intended for medium resolution applications, its single channel version accurately measures rotational speeds from zero to 20K RPM . In addition, the unit can serve as an incremental angular position encoder. (A two-channel quadrature version provides rotational direction information as well as angular position.)

Like other PAI Sensors, the magnetic / non-contact technology used in this Series provides superior reliability in industrial environments. The thermo-plastic housing is highly resistant to chemical and thermal exposure and since all the electronics are potted, seals are not needed. Greases, oils, steam / chemical wash-downs, machining chips, cutting fluids and most common industrial solvents have no effect on performance. Standard electrical features help protect the device from field service errors like reverse polarity and output short circuiting.

Central to this encoder/tachometer design are multi-pole permanent magnet target wheels. Their field patterns activate the integral Hall Effect switch and produce the output pulse train. PAI's, Series P16 target wheels are specifically designed to operate this device over the specified temperature range. Mounting options include press-fit hubs and set-screw hubs. The I.D.'s of these wheels can easily be machined to accommodate special shaft sizes. While the standard pole patterns listed in the catalog serve most applications, custom symmetric and asymmetric patterns can be produced.

PART

NUMBER

ENCODER DESCRIPTION

P9100

Single Channel Output, 22 AWG leads, 36" long

(Contact the factory for other options and P/N's)



PHOENIX AMERICA INC.

4717 CLUBVIEW DRIVE
FORT WAYNE, IN 46804

DIMENSIONAL LAYOUT

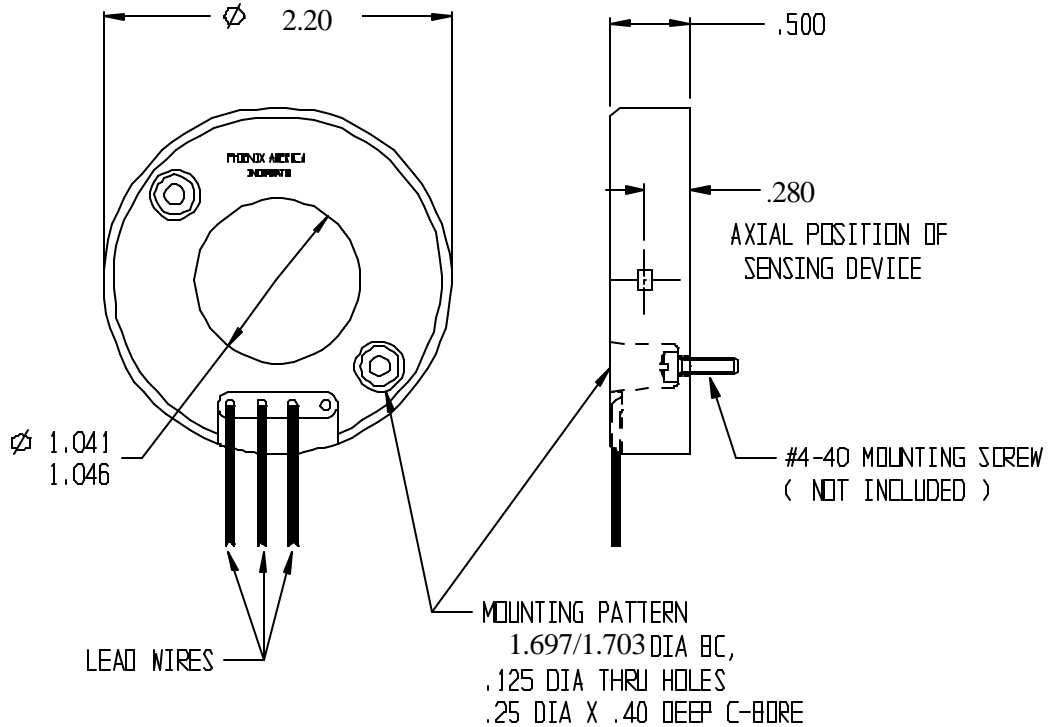

Functional Block Diagram

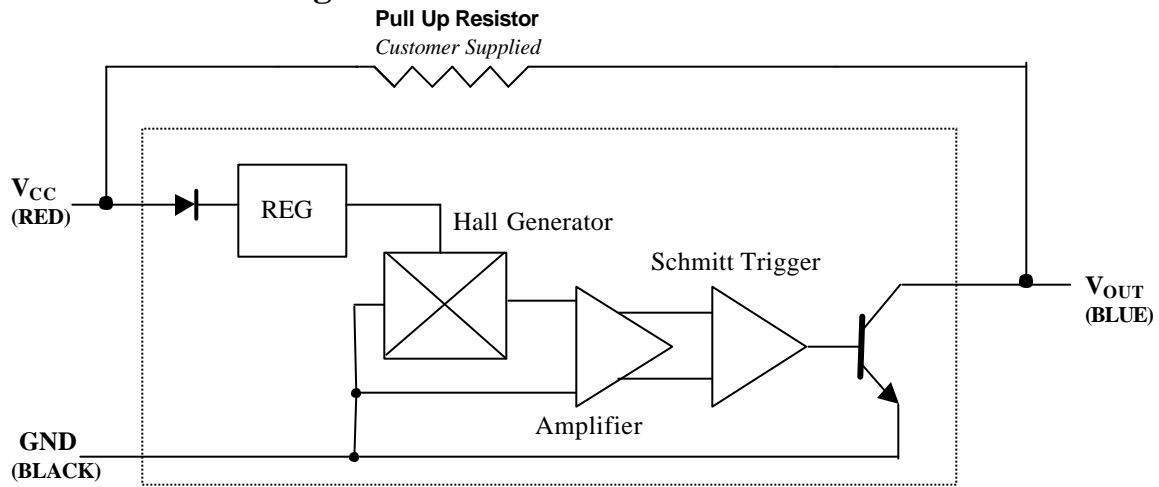

NOTE: A pull-up resistor is required on the open collector output to establish a quiescent voltage level. The pull-up resistor also provides faster rise times and improves noise immunity. Contact the factory for application assistance.



PHOENIX AMERICA INC.

4717 CLUBVIEW DRIVE
FORT WAYNE, IN 46804

Electrical Characteristics: (T = -40 to 125 °C)

Characteristics	Symbol	Test Condition	Limits			
			Min.	Typ.	Max.	Units
Supply Voltage	V_{CC}	Operating	4.5		24	VDC
Supply Current	I_S	$V_{CC} = 4.5V$; Output Open		4.7	8.0	mA
Output Current	I_{OUT}	$V_{CC} = 4.5V$; Output Open			20	mA
Output Saturation Voltage	$V_{OUT(SAT)}$	$B > B_{OP}$; $I_{OUT} = 20ma$		150	400	mV
Output Leakage Current	I_{OFF}	$B < B_{RP}$; $V_{OUT} = 24V$		4.7	8.0	uA
Rise/Fall Time	t_r / t_f	$R_L = 1.2k$; $C_L < 33pF$			1	us

Magnetic Characteristics: ($V_{CC} = 4.5$ to 24 VDC @ 25°C)

Characteristics	Symbol	Limits			
		Min.	Typ.	Max.	Units
Operating Point	B_{OP}	15	50	75	Gauss
Release Point	B_{RP}	-75	-50	-15	Gauss
Hysteresis	B_{HYS}	30	100	150	Gauss
Maximum Field Exposure	B_{MAX}	-800		800	Gauss
Active Element Depth	D_p			0.021	Inch